

# PRODUCT ID: 32336

## Alarm Unit

### MODEL

PA-WF-LV

### DIMENSIONS

1.41" H x 1.41" W x 1.7" D (est. 0 lbs)

### ELECTRICAL

Input Voltage:

## Product View

NOTE: Sign image may not exactly represent the finished product. For illustration purposes only.

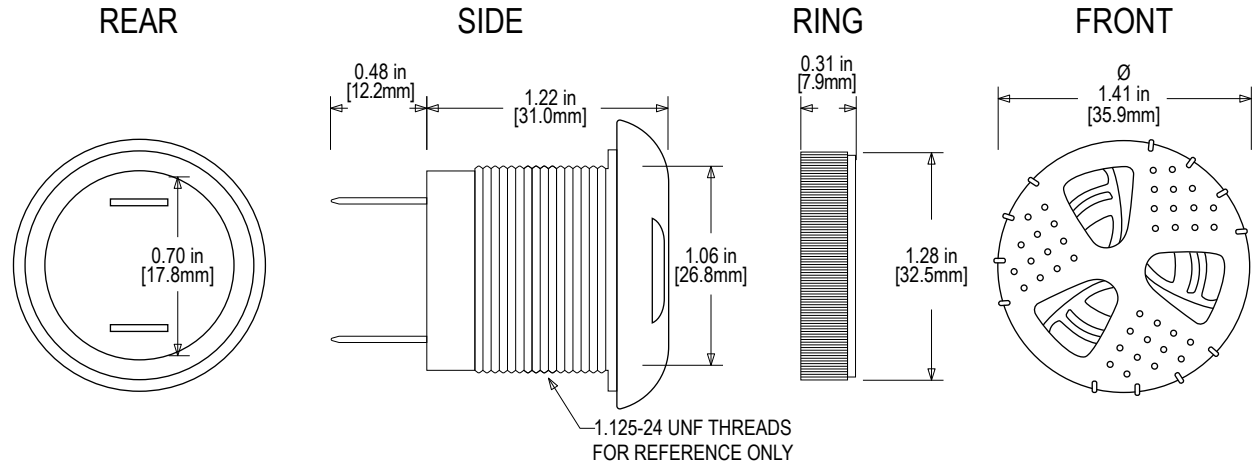

### "Q" TERMINALS

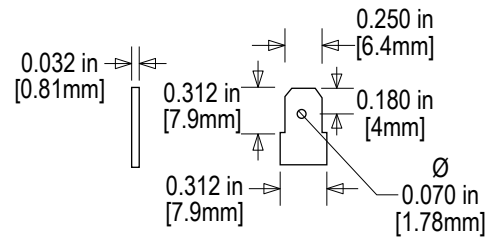

### PANEL MOUNTING

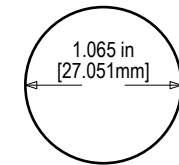

FITS PANELS UP TO 0.50in [12.7mm] THICK

TOLERANCES ARE ±0.03in [±0.76mm] UNLESS OTHERWISE SPECIFIED

### Directional Systems

2201 W 50th St.

Erie, PA 16509

Phone: (877) 827-8296

Fax: (877) 827-8291

Email: sales@directionalsystems.com

Website: www.directionalsystems.com

